

ELEVATION

POST MOUNTING OPTIONS  
 SURFACE MOUNT  
 SIDE MOUNT  
 CORE-IN

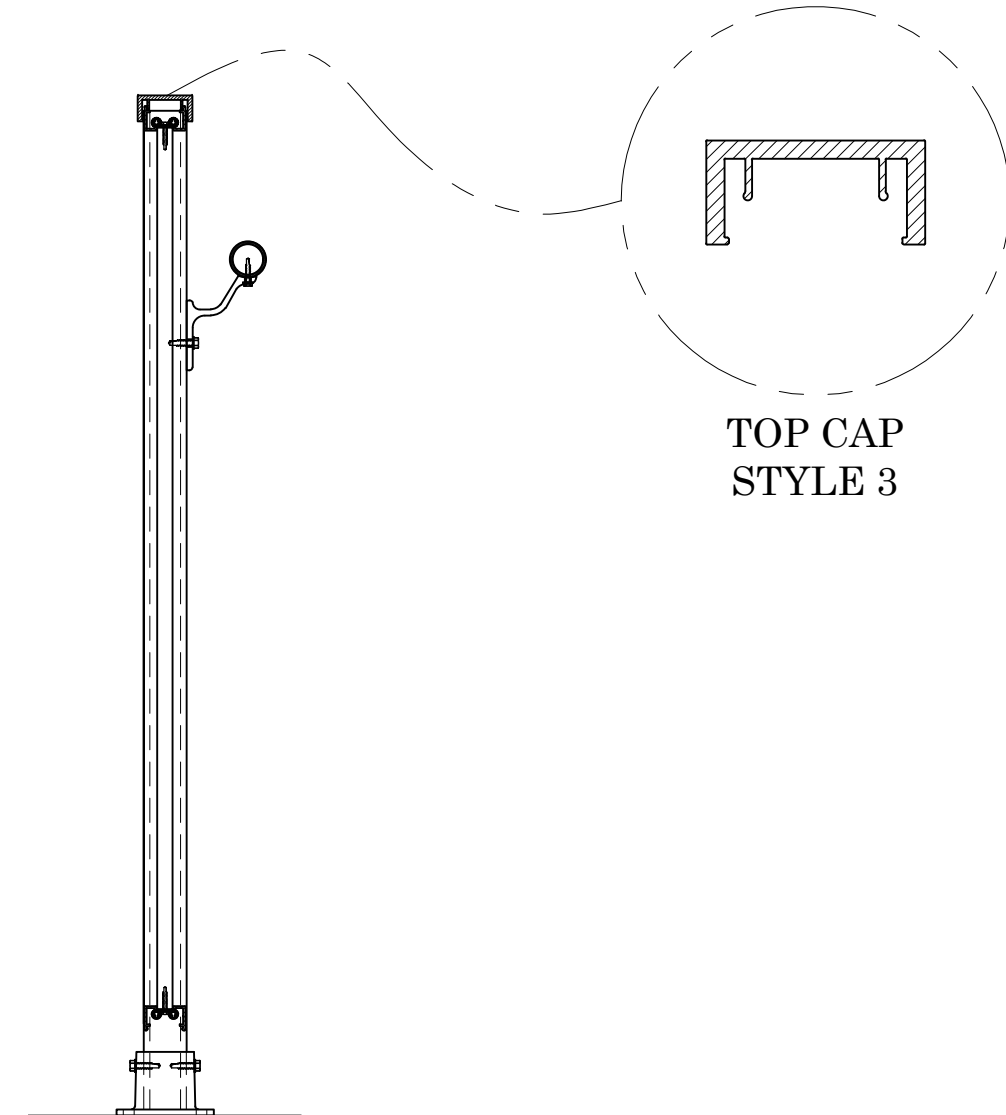

CUT-SECTION

TOP CAP  
 STYLE 3

M200-3A W/ ASSIST MATERIALS	
TOP CAP	2¼" x 1" TOP CAP (STYLE 3)
POST	1¾" SQUARE POST
CHANNEL	1⅝" x 1" CHANNEL
PICKET	⅝" SQUARE PICKET (STYLE A)
ASSIST RAIL	1¼"Ø SCH40 ALUMINUM PIPE (1.66" O.D.)
RAIL BRACKET	EXTRUDED ALUMINUM AT 1½" WIDE



8301 Strimple Rd.  
 Cleves, Ohio 45002  
 p 513 353-1116  
 f 513 353-2116

M-SERIES ALUMINUM RAILING

DESIGN# M200-3A W/ ASSIST

DRAWN BY:	DTB	REVISIONS:
DATE:	03/24/2022	
SCALE:	NOT TO SCALE	
SHEET #:	M200-3A ASSIST	